

BIRDS-EYE-VIEW OF A WINDOW
OPENING AND WINDOW SILL REVEAL.

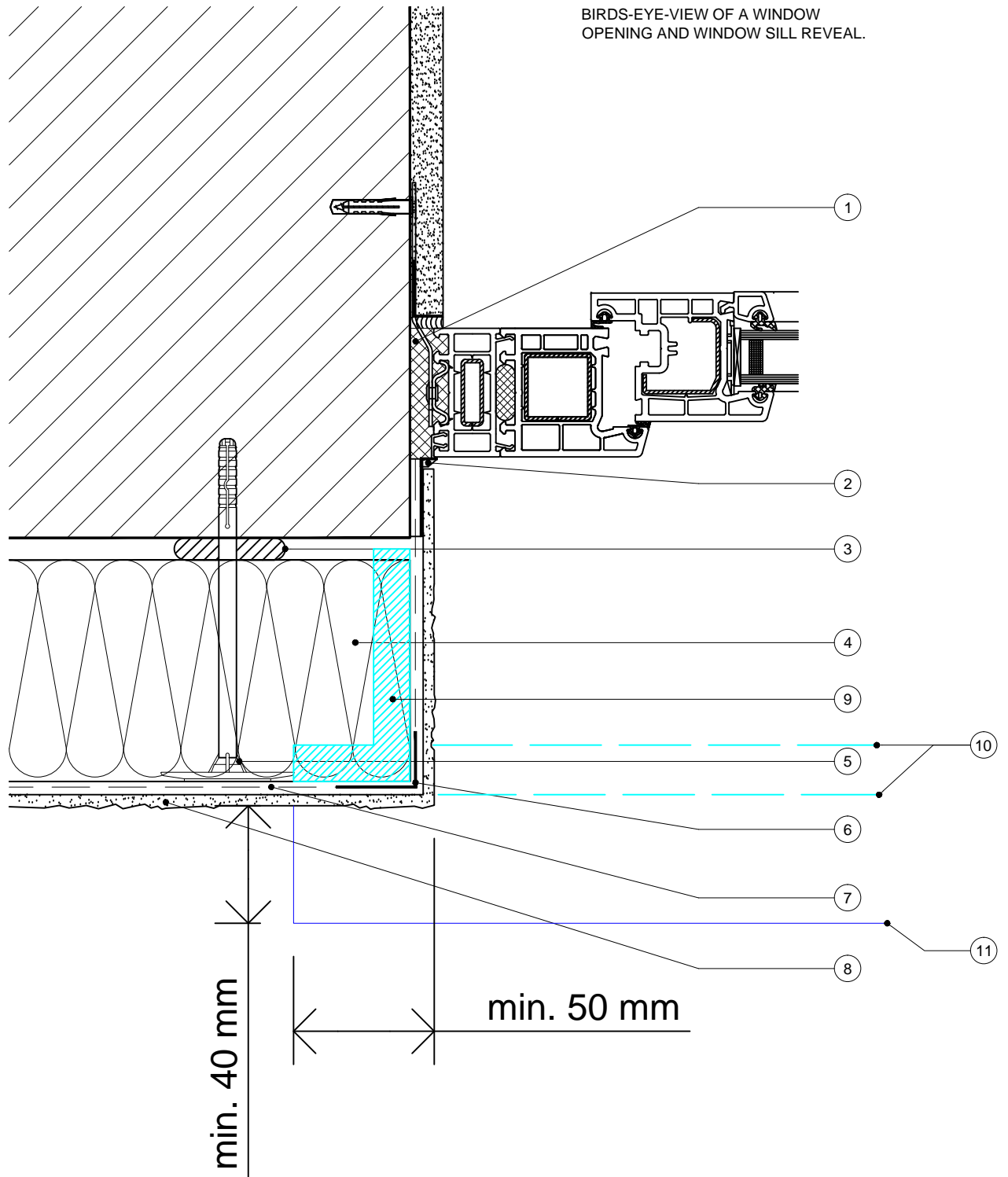

1. Window Frame
2. Apu/Window Reveal Bead.
3. Insulation Adhesive.
4. Insulation.
5. Mechanical Fixing.
6. External Corner Bead.
7. Basecoat + Fibreglass Mesh.
8. Topcoat.

9. Expanding sealing type between top of window will or oversill and underside of insulation.
10. Expanding sealing type to underside of sill.
11. Window sill or window oversill

DRAWING TITLE: External insulation installed to a recessed opening with a non-insulated reveal



DRAWING No: EP - 006

DATE: 09-02-2022

SCALE: NTS

REFERENCES:
WRD-WJ003

EWI Pro Insulation Systems LTD.
Kingston Bussines Centre Unit1
Fullers Way South
Chessington KT9 1DQ